

Water Chiller Add-On Module

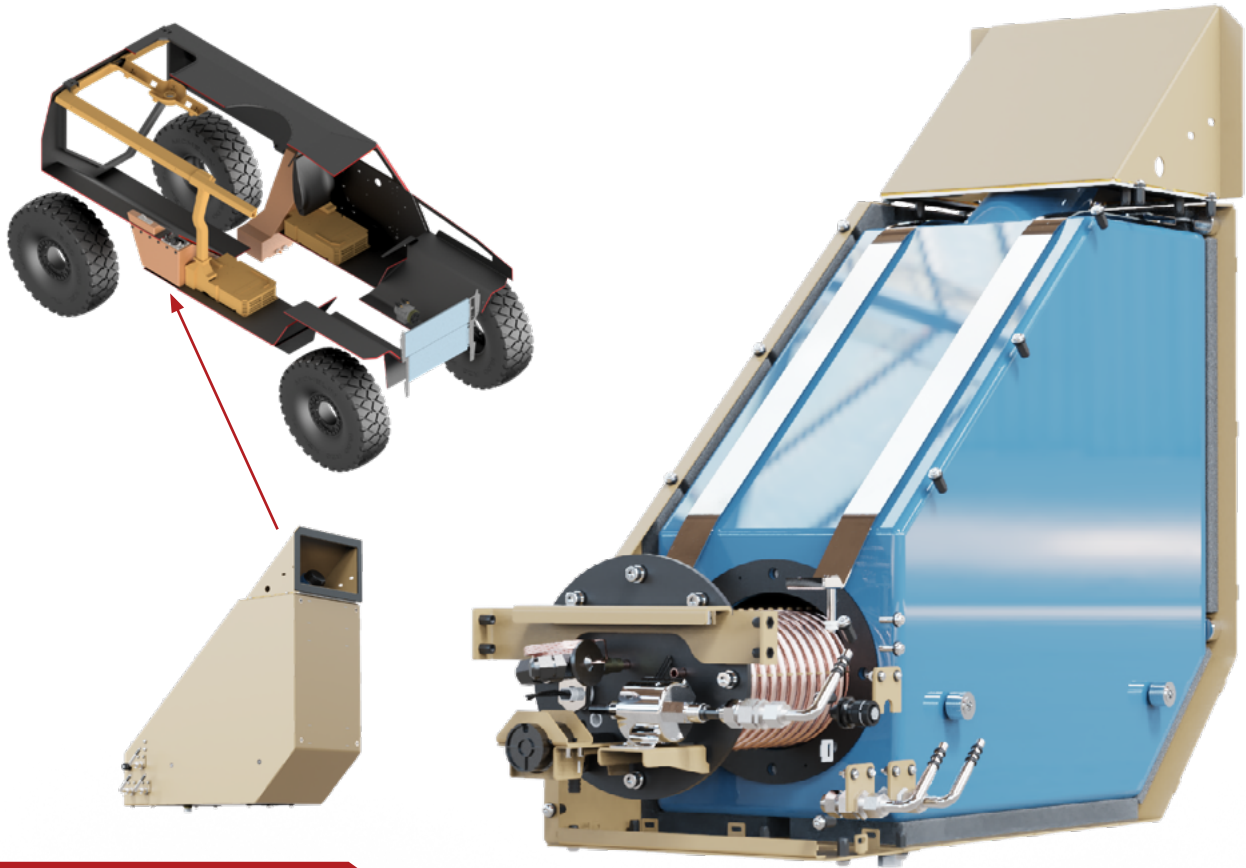

ADD-ON DRINKING WATER COOLER INTEGRATED INTO MAIN VEHICLE
HVAC UNIT



Ref. WCLM13-3

SPECIFICATION

Cooling Capacity	2-4kW Water Cooling Options
Reservoir	60litres Drinking Water
Cooling time 60%	< 30 mins from 30°C to 10°C
Refrigerant	R134a
Total Weight	80kg (Full reservoir)
Dimensions	740mm L x 380mm W x 850mm H
Construction	LLDPE Plastic Water Tank with Stainless Steel Enclosure

Optional

UV-C Filtration A UV-C filtration module for the water can be offered

FRONT, SIDE AND TOP VIEW

(Max Overall Dimensions 0,74 m long x 0,38m wide x 0,85 m high, weight 80kg)

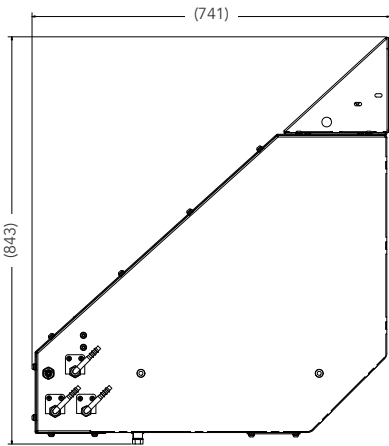

LEFT VIEW

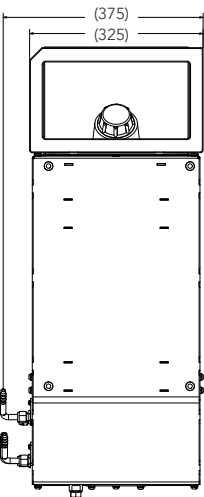

FRONT VIEW

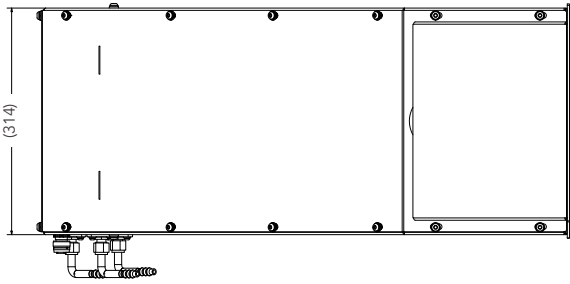

TOP VIEW

ISOMETRIC VIEWS

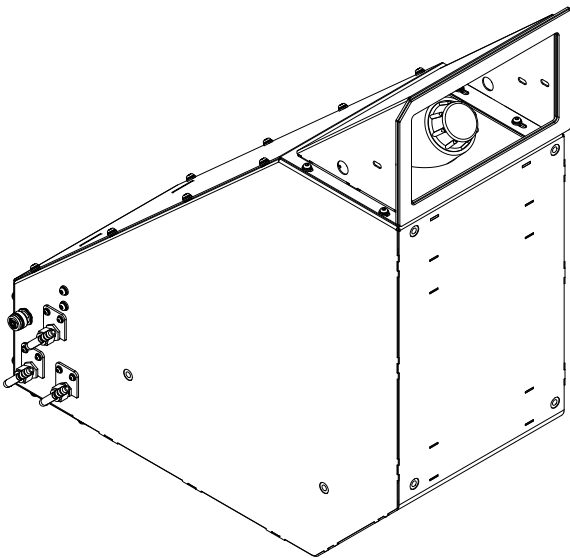

RIGHT HAND ISOMETRIC VIEW

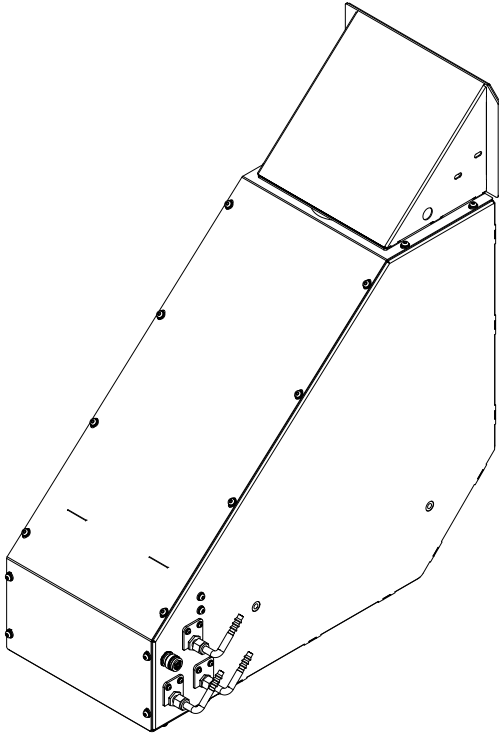

LEFT HAND ISOMETRIC VIEW

