

# Water Chiller Add-On Module

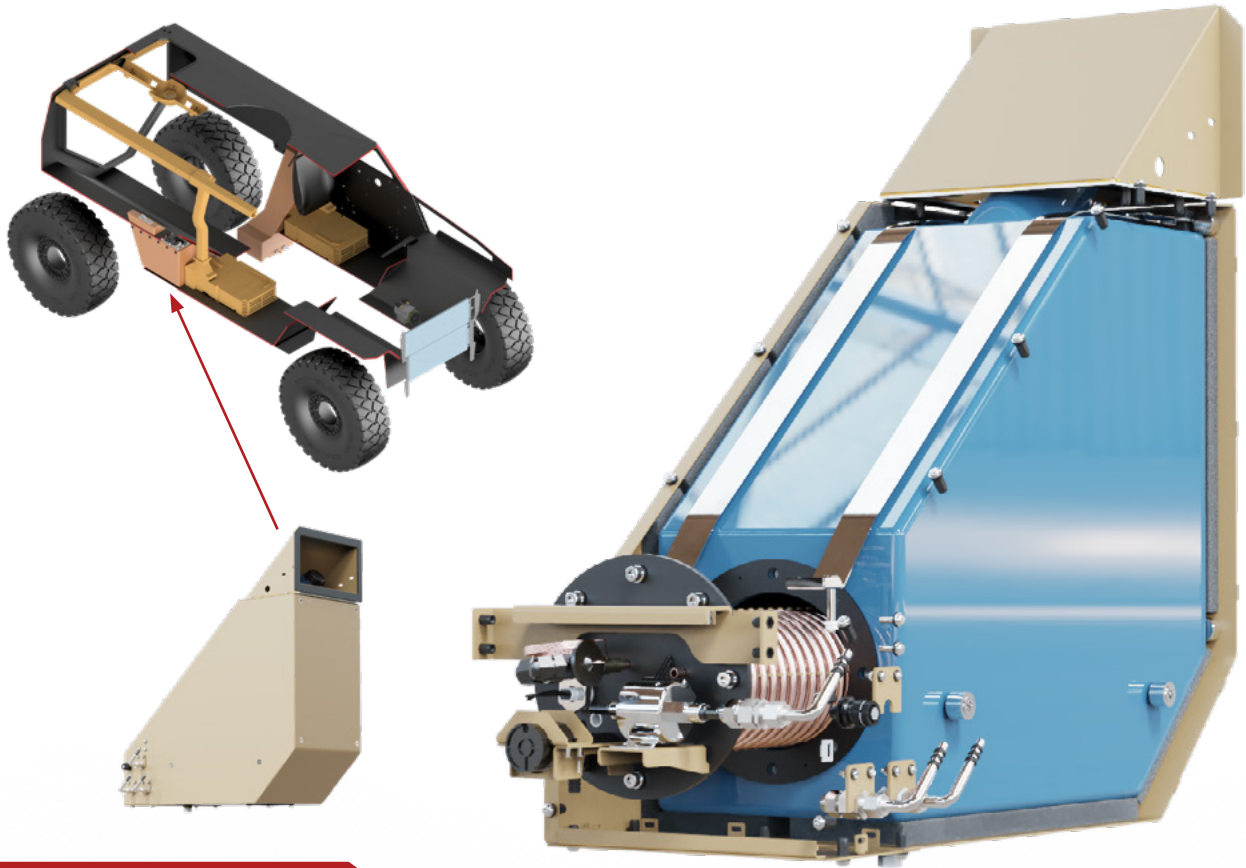

ADD-ON DRINKING WATER COOLER INTEGRATED INTO MAIN VEHICLE  
HVAC UNIT



Ref. WCLM13-3

## SPECIFICATION

<b>Cooling Capacity</b>	2-4kW Water Cooling Options
<b>Reservoir</b>	60 Litres Drinking Water
<b>Cooling time 60ℓ</b>	< 30 mins from 30°C to 10°C
<b>Refrigerant</b>	R134a
<b>Total Weight</b>	80kg (Full reservoir)
<b>Dimensions</b>	740mm L x 380mm W x 850mm H
<b>Construction</b>	LLDPE Plastic Water Tank with Stainless Steel Enclosure

## OPTIONAL

**UV-C Filtration** A UV-C Filtration Module for the water can be offered

# FRONT, SIDE AND TOP VIEW

(Max Overall Dimensions 0,74 m long x 0,38m wide x 0,85 m high, weight 80kg)

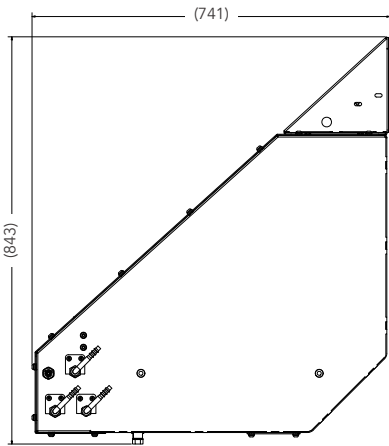

LEFT VIEW

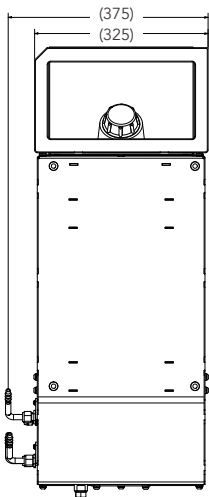

FRONT VIEW

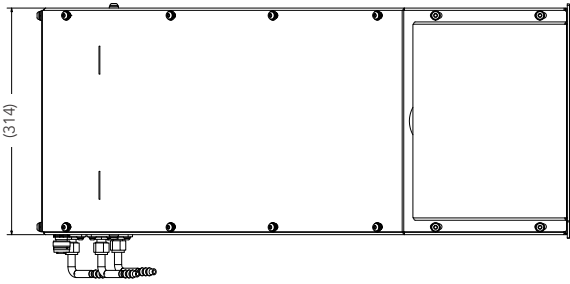

TOP VIEW

# ISOMETRIC VIEWS

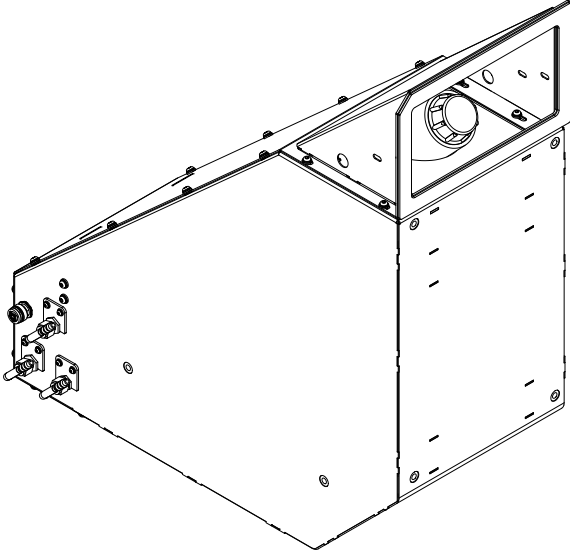

RIGHT HAND ISOMETRIC VIEW

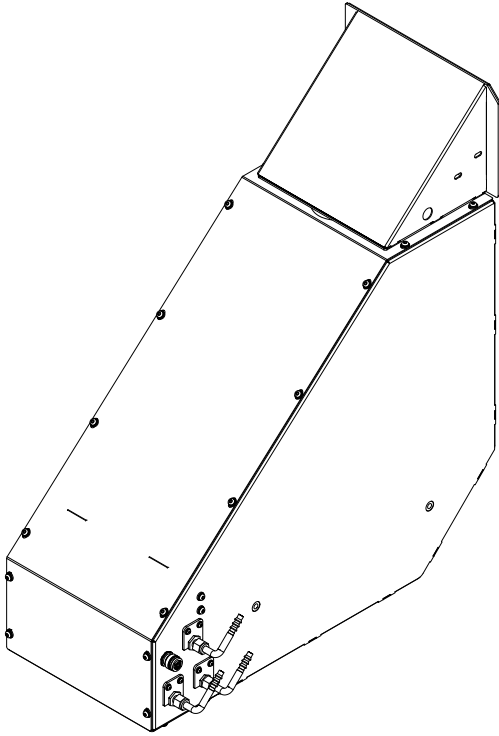

LEFT HAND ISOMETRIC VIEW

